

# SINGLE TRANSISTOR OVERDRIVE

**CIR-KIT™ BUNDLE GUIDE**



**DIY**

BY COPPERSOUND PEDALS

# INCLUDED COMPONENTS

## Potentiometers

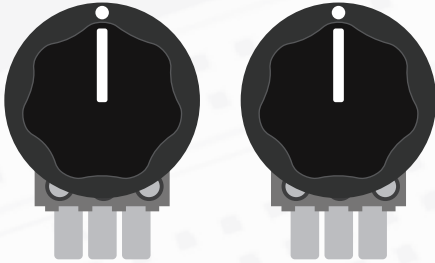

B100K  
x2

## Precut Wire

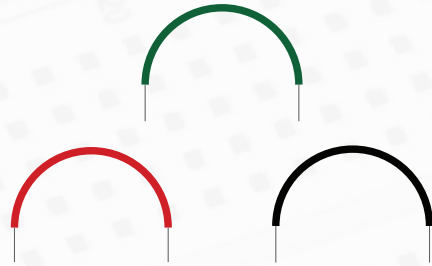

1.5" Red, Black, Green  
x30

## Transistors & Capacitors

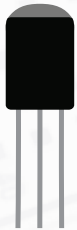

Transistor  
2n3904  
x1



Film Caps  
(various)  
x4

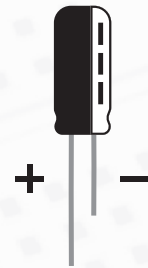

Electrolytic Cap  
100u  
x1

## Resistors & Diodes



Diode  
1n4148  
x2



Resistors  
(various)  
x5



Diode  
1n4001  
x1

# HOW BREADBOARDS FLOW

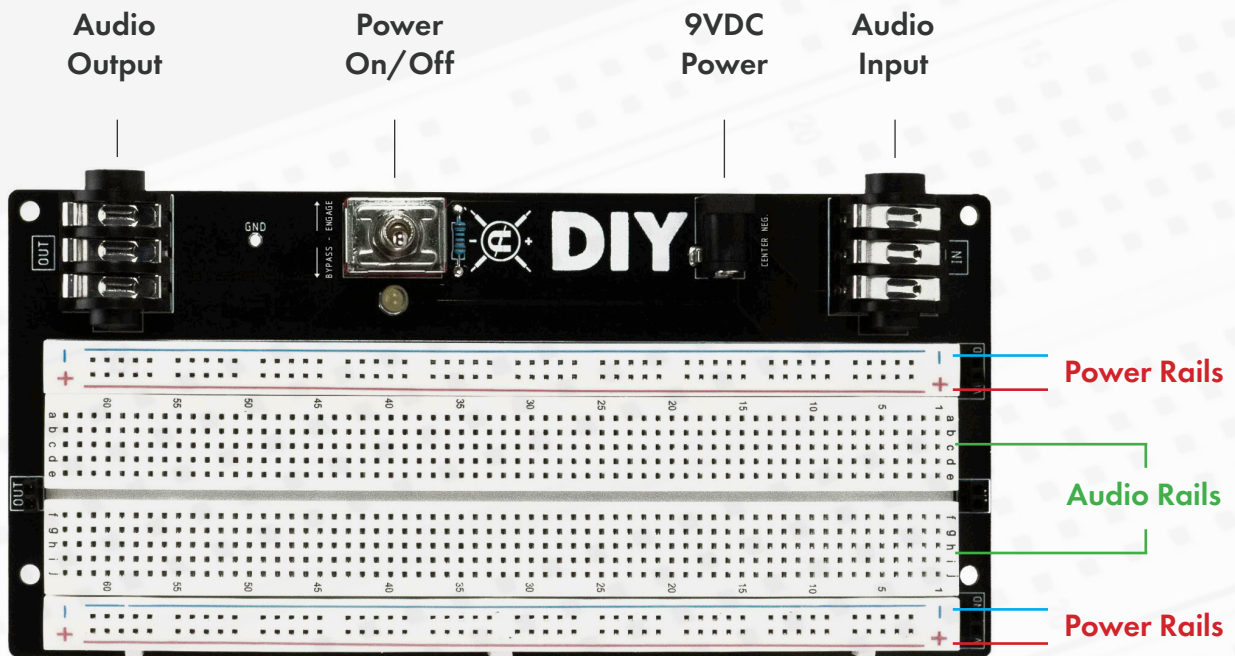

## Power rails flow horizontally.

The **negative** rail will connect to the pin header marked **GND**, and the **positive** rail will connect to the pin header marked **VCC**.

## Audio rails flow vertically.

Channels **a-e** are connected, and channels **f-j** are connected.

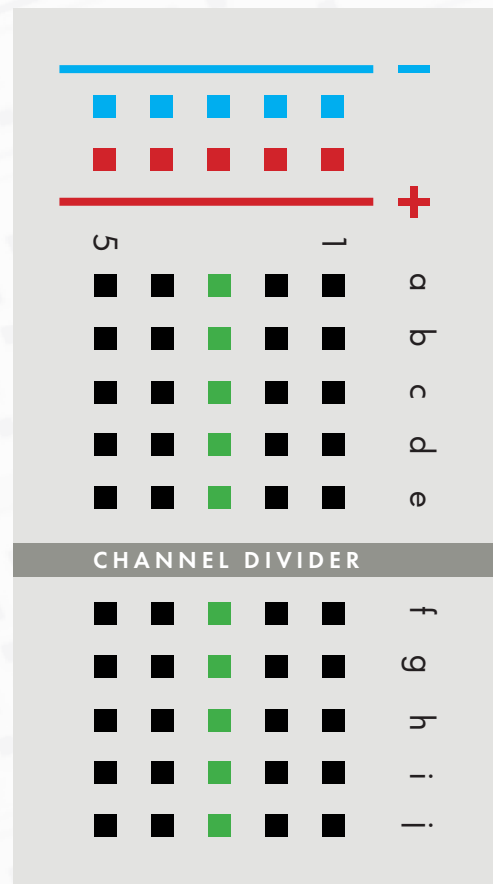

# READING RESISTORS

Reading resistors may seem intimidating, but it's a very important aspect of breadboarding and is actually very easy! To determine the resistor value, follow the table and colors below. To ensure you are reading the correct value, keep in mind that the tolerance band is always found on the far right.



COLOR	1ST BAND	2ND BAND	3RD BAND	DECIMAL MULTIPLIER		TOLERANCE	
BLACK	0	0	0	1	1		
BROWN	1	1	1	10	10	±	1%
RED	2	2	2	100	100	±	2%
ORANGE	3	3	3	1K	1,000		
YELLOW	4	4	4	10K	10,000		
GREEN	5	5	5	100K	100,000		
BLUE	6	6	6	1M	1,000,000		
VIOLET	7	7	7	10M	10,000,000		
GRAY	8	8	8		100,000,000		
WHITE	9	9	9		1,000,000,000		
GOLD					0.1	±	5%

Shown below are the resistors and values that we'll be using in this build.

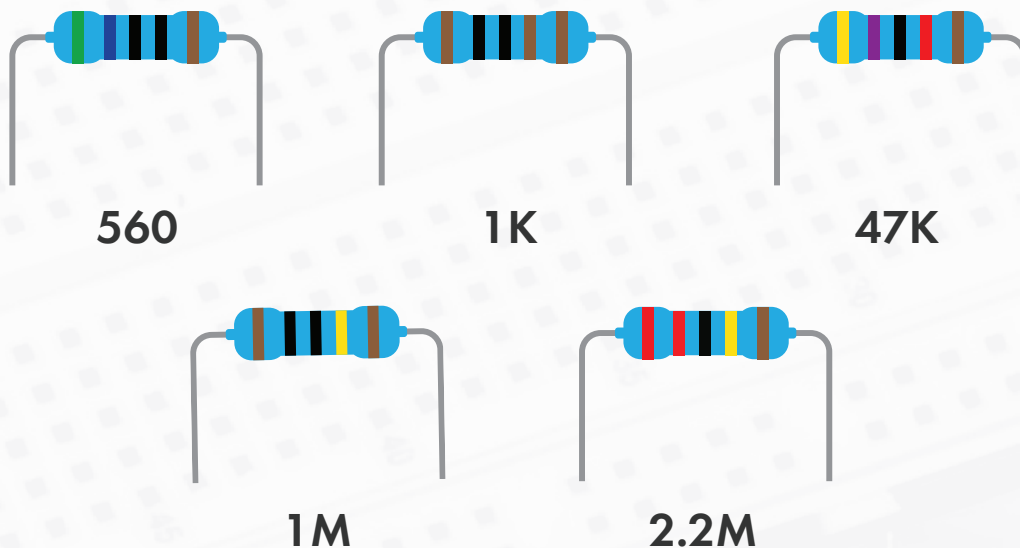

# STEP ONE | POWER FILTERING

Power filtering helps to filter unwanted noise from power supplies, while preventing incorrect polarity from damaging the circuit. Ensure that polarized components (diode + electrolytic capacitor) are inserted correctly. In the schematic below, the power shows 9V, whereas the breadboard shows VCC. Please note that for the majority of pedal circuits, these terms are interchangeable.

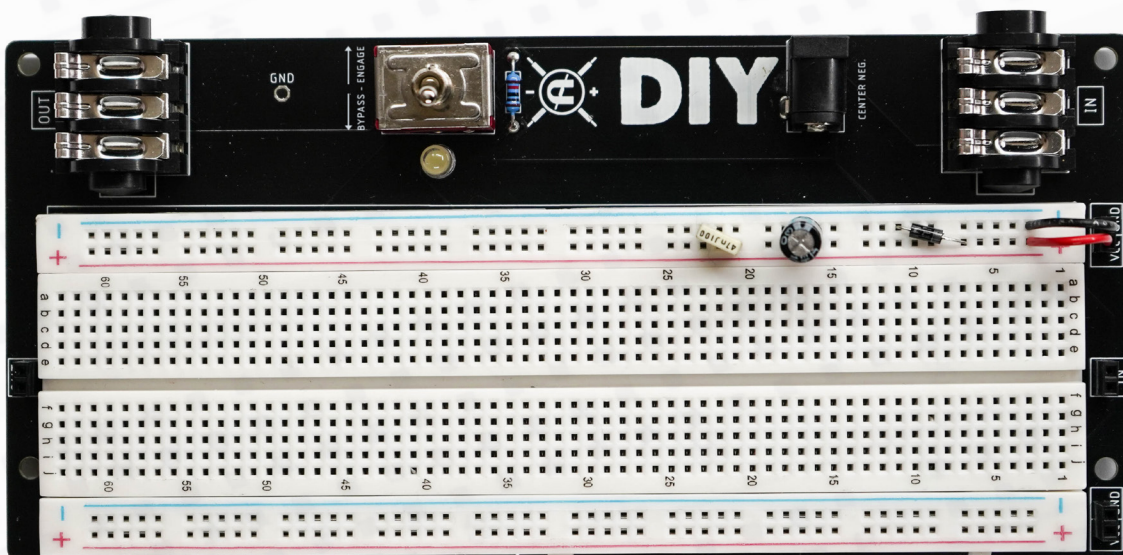
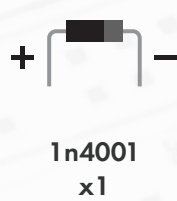
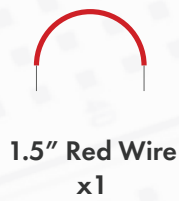
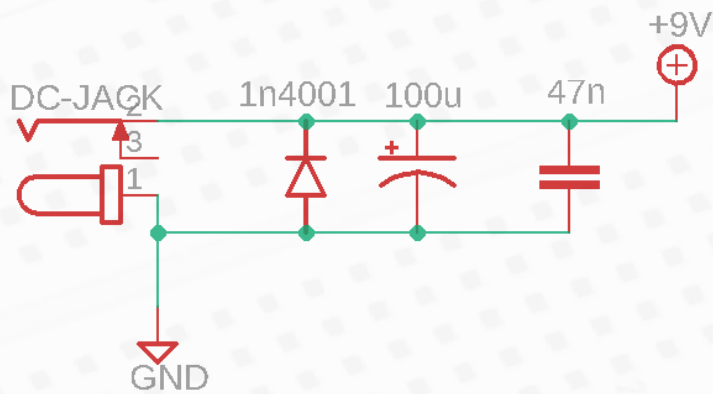

## STEP TWO | INPUT

The input capacitor blocks AC while setting the amount of lows allowed into the circuit, and the pull down resistor prevents popping from the switch.

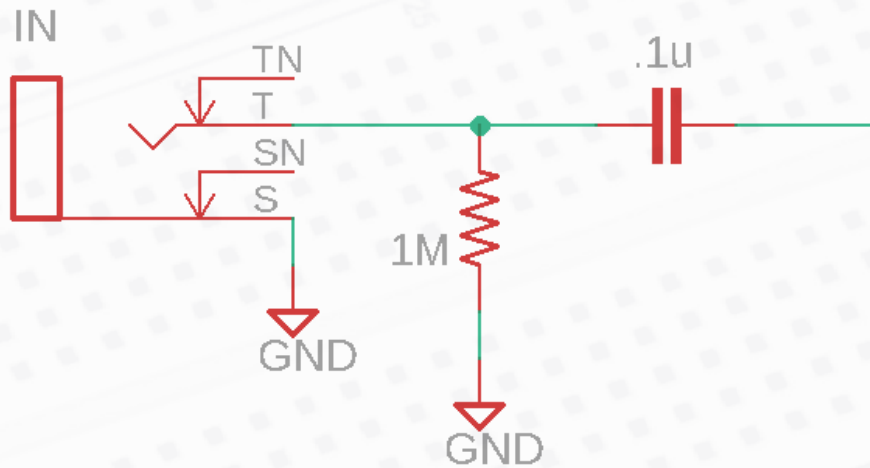

1.5" Green Wire  
x1



1M  
x1



.1u  
x1

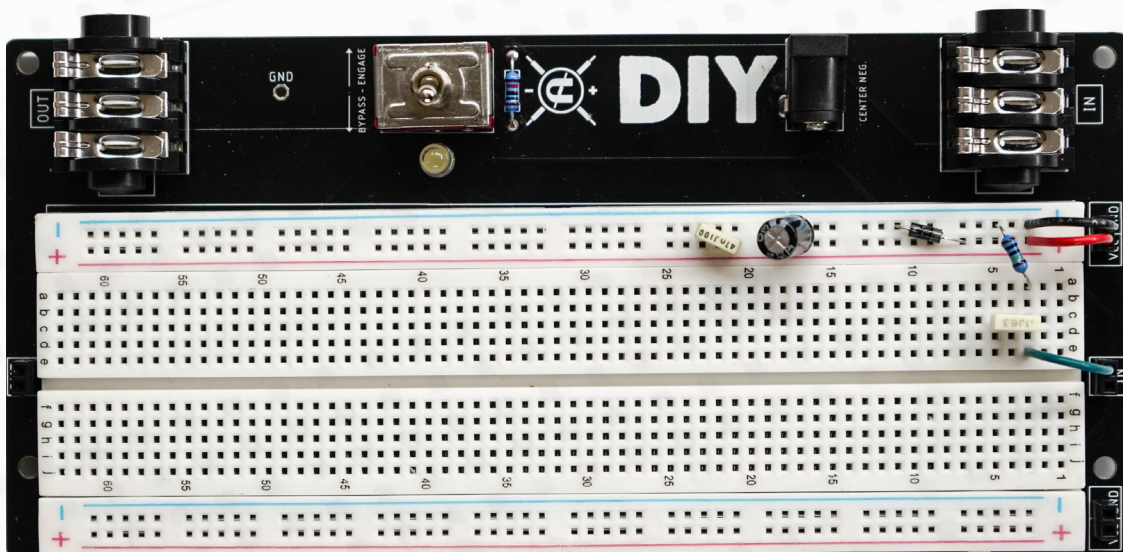

# STEP THREE | GAIN SECTION

These resistors set the voltage biases of the transistor.

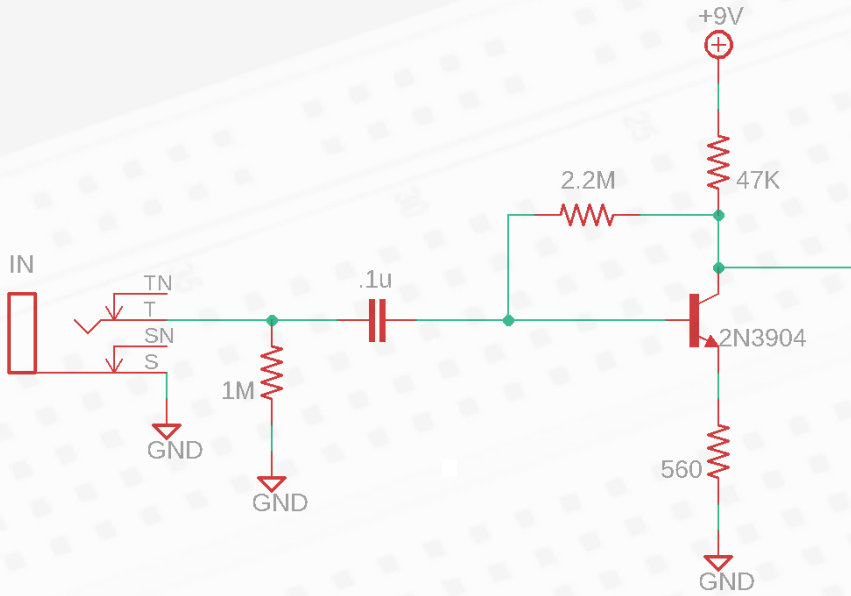

TRANSISTOR PINOUT

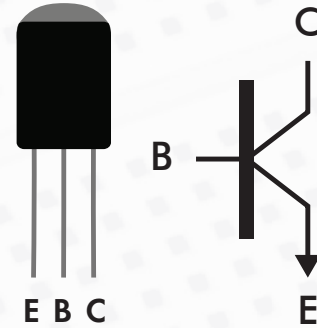

1.5" Green Wire  
x2



2.2M  
x1



47K  
x1



560  
x1



2n3904  
x1

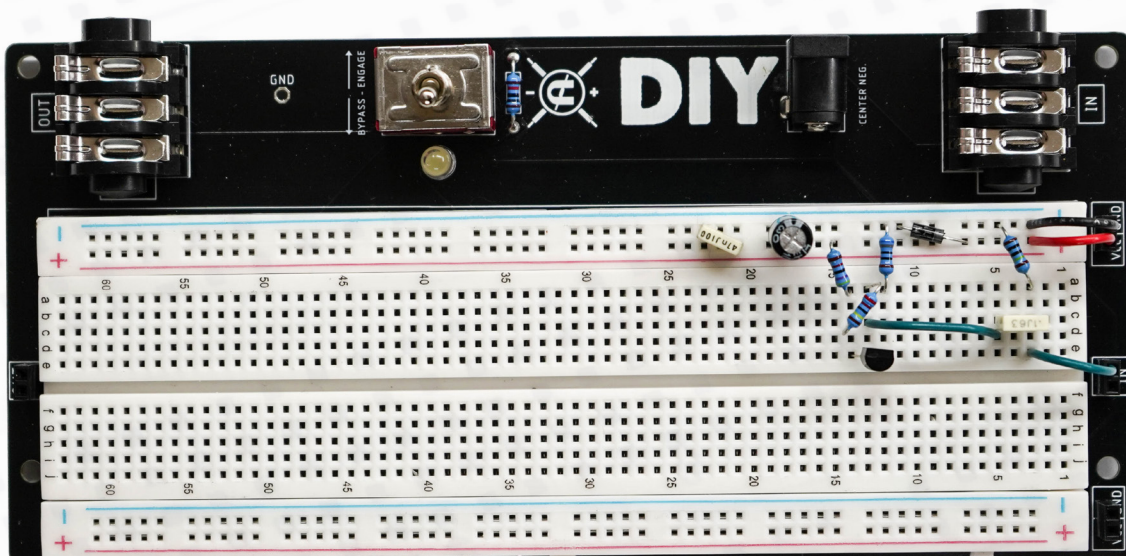

# STEP FOUR | CLIPPING SECTION

The output capacitor blocks AC while setting the amount of lows that go to the output. The diodes shunt some of the signal to ground causing the waveform to cut off and produce distortion.

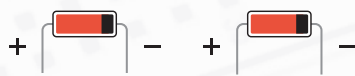
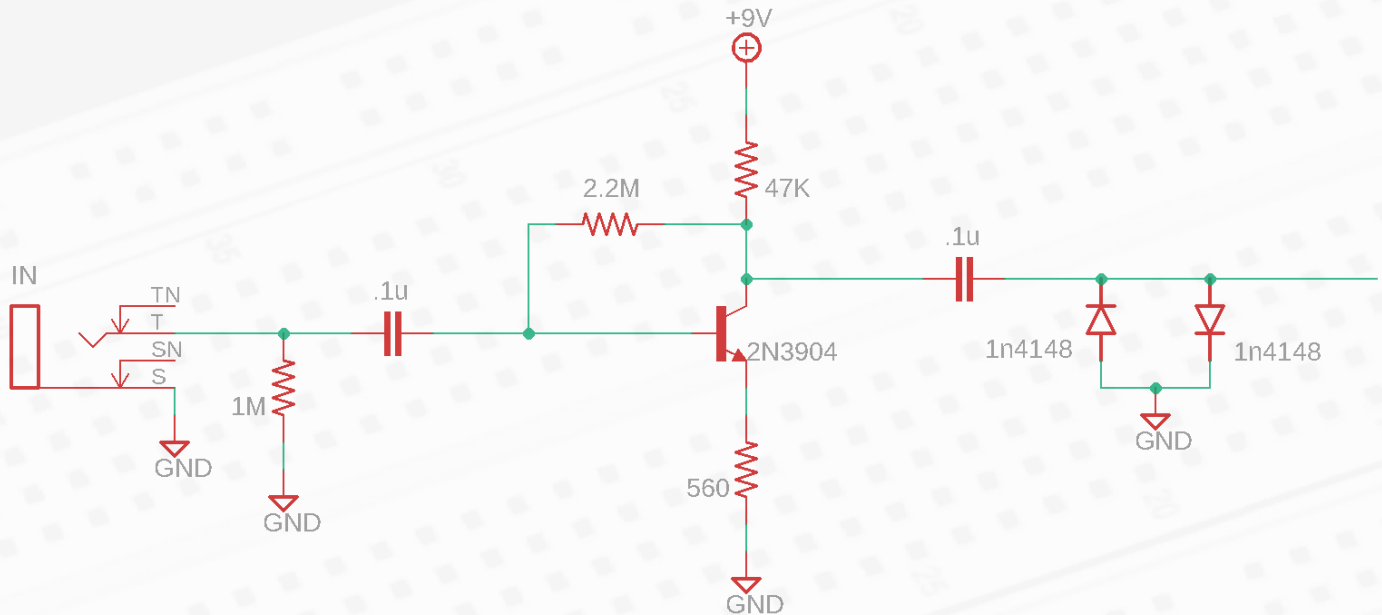

1n4148  
x2



1.5" Green Wire  
x2



.1u  
x1

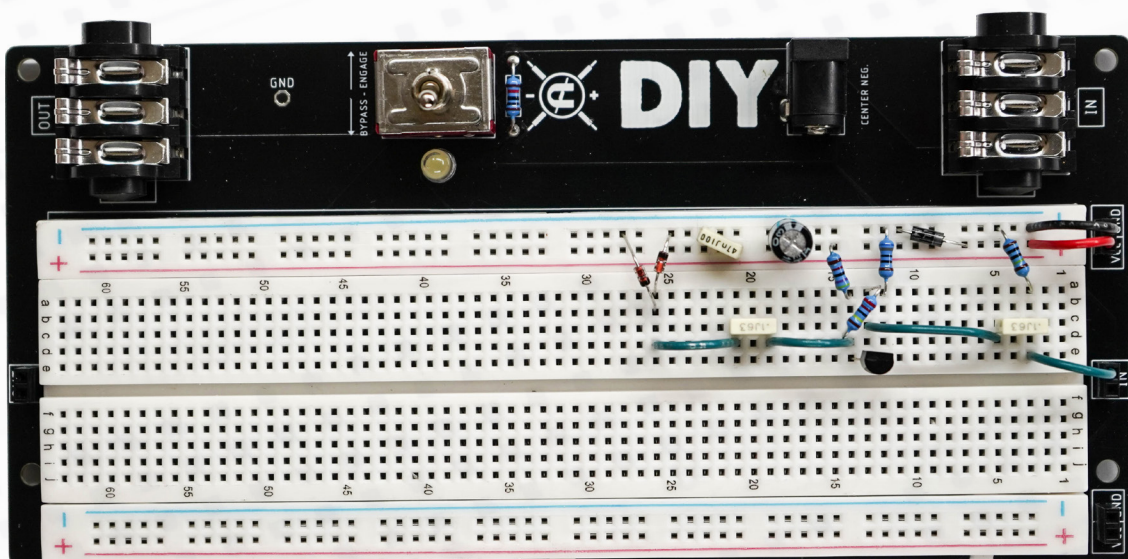



# STEP FIVE | TONE SECTION

The resistor/capacitor(RC) network create a low-pass filter(LPF) and the the tone knob determines the frequency of the high cut.

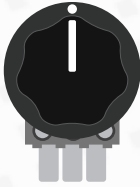
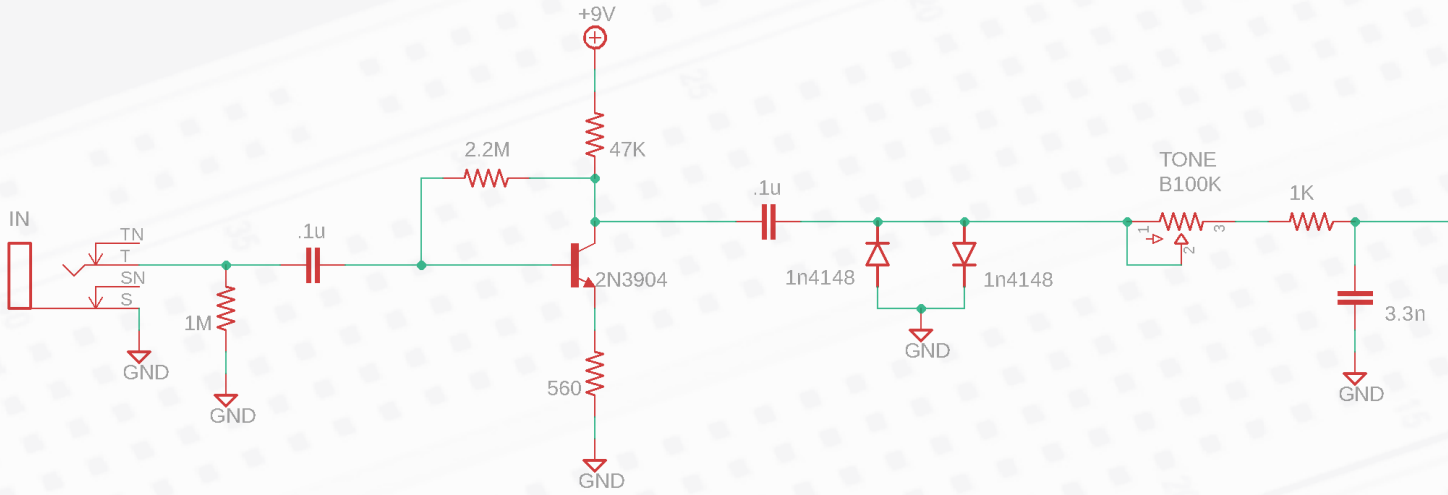

**B100K**  
x1



**3.3n**  
x1



**1K**  
x1



**1.5" Green Wire**  
x2

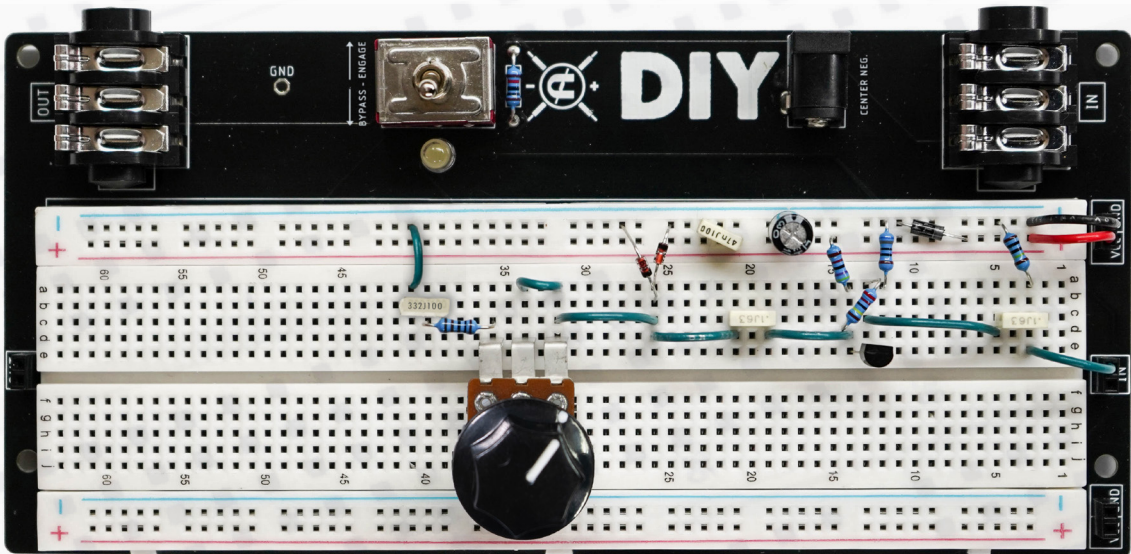

# STEP SIX | OUTPUT

The volume knob acts as an attenuator, setting the output volume of the circuit.

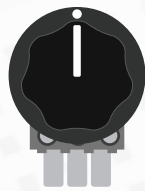
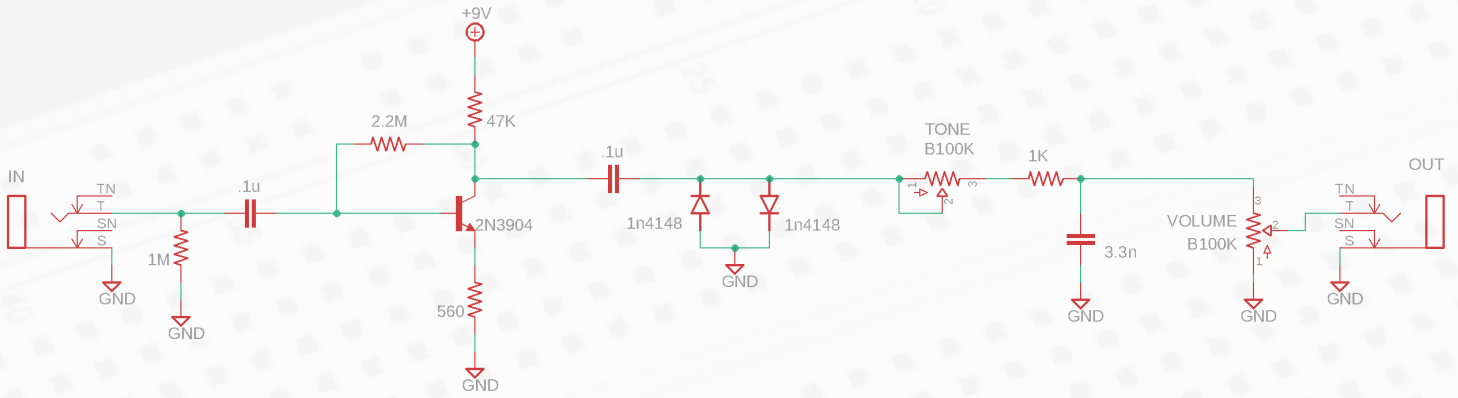

**B100K  
x1**



**1.5" Green Wire  
x3**



**1.5" Black Wire  
x1**

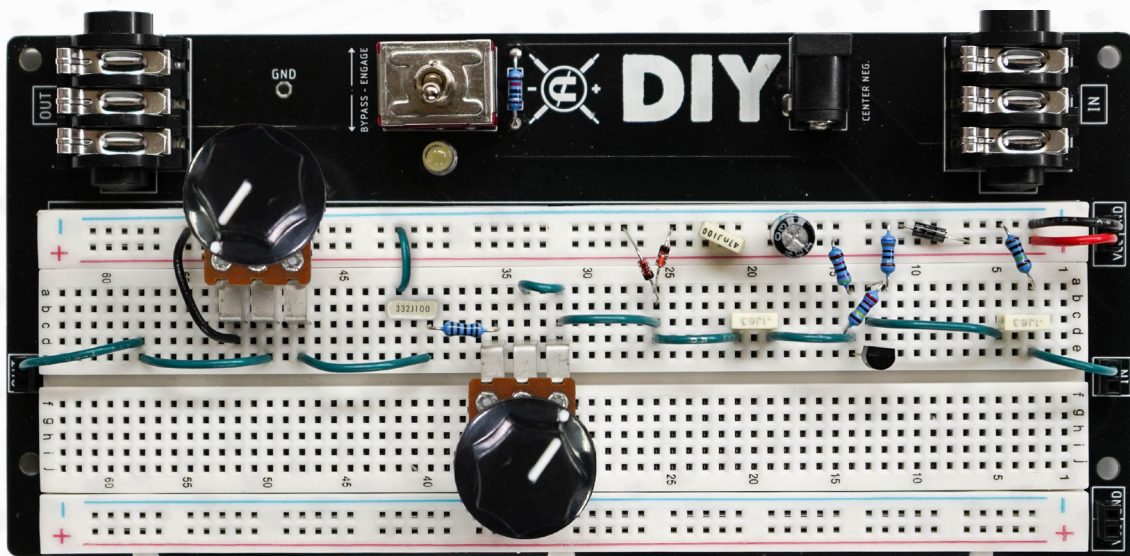

# TROUBLESHOOTING

**Not getting power to the Power Rails/LED is not turning on when the toggle switch is set to the 'Engage' position.**

Check that the proper connections are being made from the "VCC" & "GND" pin headers to the Power Rails. Pay attention to the orientation of Polarized components (Diodes and Electrolytic Capacitors).

Check the polarity of your power supply. Breadboards require "Center negative" polarity (as is with the power supply shipped with the bundle).

**Not getting any effect when the toggle switch is set to the Engage position.**

Most common issues will pertain to the proper connections being made. This could be as simple as a component being 1 slot away from the correct Audio Rail.

Check that transistors are in the correct orientation, and not flipped around 180 degrees.

**Getting effect when toggle switch is set to Engage, but it doesn't sound as expected.**

Check that the transistor is in the correct orientation and not flipped around 180 degrees. Check that the resistors are in the correct place and didn't get swapped with a different value. Pay attention to the orientation of Polarized components (Diodes and Electrolytic Capacitors).

**Still stuck? Please reach out to us with any questions you have! We're here to help. Email us at:**

[diy@coppersoundpedals.com](mailto:diy@coppersoundpedals.com)

